

# DRIVE OVER

---

BELT CONVEYOR



*Complimented by Comparison.*

MOVES A WORLD OF GRAIN  
**Hutchinson** *Drive over convenience. Belt conveyor capacity.*  
 THE WORLD OVER

**INCLINE LENGTH**

Standard incline section length is 64" (163 cm). Up to 5' (2 m) of additional length may be requested, which provides up to 20" (51 cm) of additional discharge height.



**DISCHARGE SPOUT**

The large discharge outlet features a full 16" x 21" (41 x 53 cm) rectangular outlet. The spout is fully adjustable and sits a full 3'-4" (.91 m-10 cm) above the ground.

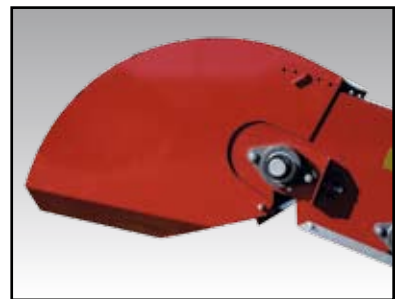

**BELT DESIGN**

The 24" (61 cm) belt features a PVC crescent pattern with slider bed backing, stainless steel belt splice and a 42 1/2" (107 cm) hopper shield dump area.

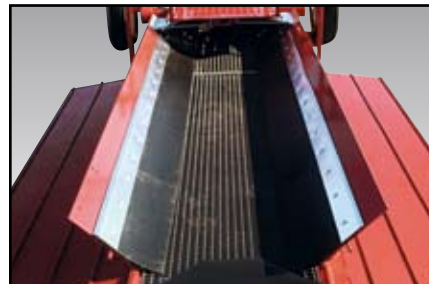

**DRIVE-OVER**

The full 7' x 10' (2 x 3 m) wide area provides a convenient, safe design for high capacity dumping. The system is engineered so the ramps and dumping area are fully integrated into a single unit. The low profile drive over only requires a minimal 5-1/2" (14 cm) clearance.



**UNDERCARRIAGE**

The system rotates using a hydraulic cylinder for lift as standard equipment. An optional screw jack is also available.



**SPRING LOADED BELT TAKE UP**

The spring loaded belt take up enables greater drive efficiency and lower belt tension requirements. Includes snub pulley for slip-free operation.



**BELT ALIGNMENT GUIDE**

Exclusive belt alignment guide rollers maintain proper belt tracking for optimum belt life (Patent Pending).



**EXCLUSIVE WALK ACROSS PLATFORM AND HANDRAIL**

The walk across platform provides safety and accessibility when unloading semi trailers and other grain hauling equipment.



**DRIVE OPTIONS**



Hydraulic Drive



Electric Drive



PTO Drive

# Drive Over Belt Conveyor

## Key Benefits

- Low drive-over clearance requires only 5-1/2" (14 cm) clearance.
- Extra wide 24" (61 cm) belt.
- Smooth transition from horizontal to incline.
- Optional greater discharge height.
- Higher capacity with lower belt speeds.
- PTO drive choices.
- Undercarriage lift choices.
- Receive from side dump wagons, as well as bottom dump and rear dump vehicles.
- S-type drive on return belt for greater drive efficiency and lower belt tension requirements. Includes snub pulley to give greater wrap at drive pulley for slip-free operation.
- Spring loaded belt take-up for lower operating belt tensions.
- Guide roller assembly to keep belt tracking properly.
- Removable hitch tube.
- Self cleaning wing type tail pulley.

## General Specifications

### INCLINED TROUGH:

### DRIVE:

### UNDERCARRIAGE (Standard):

### UNDERCARRIAGE (Optional):

### OPERATING BELT SPEED:

### CAPACITY:

### HORSEPOWER REQUIRED:

- Flat bottom, troughed edges, 10 gauge, 20 degree inclined angle.
- S-Drive on crescent face of belt w/spring loaded take-up, lagged drive pulley. Conveniently located under the incline section.
- Rotating arm design using a hydraulic cylinder.
- Rotating arm design using a screw jack for lift.
- 600-800 feet (183-244 m) per minute.
- Up to 10,000 bushels per hour (280 mth).
- 10 HP electric. Hydraulic drive capacity minimum 20 gal./min. (15 HP for drive over belt with 5' 4" extended incline section)

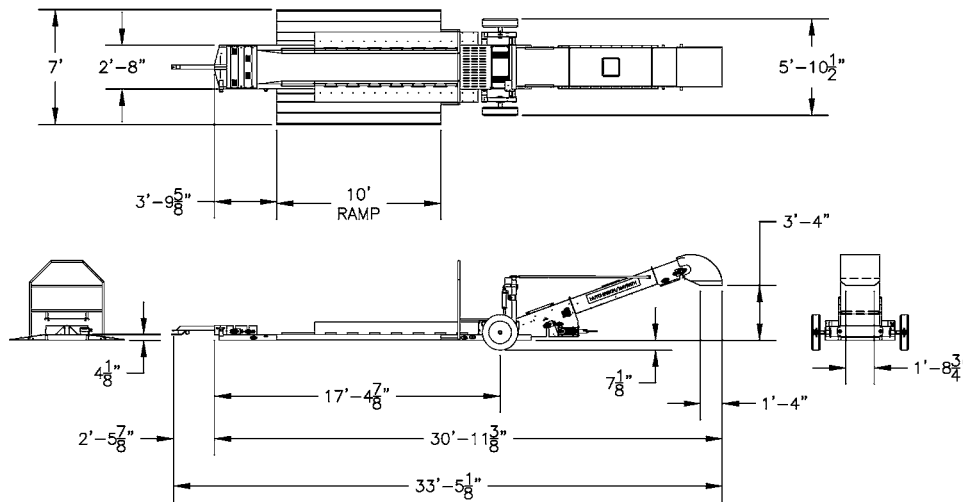

Call Toll-Free

**1-800-523-6993**

For more information.



Distributed by:

A Division of GLOBAL Industries, Inc.  
 P.O. Box 629 • Clay Center, KS 67432  
 Ph. (785) 632-2161 • FAX (785) 632-5964  
 www.hutchweb.com

BAC 38888/1/07

Printed in U.S.A.